

## RESEARCH ON MULTI-LEVEL INDICATOR OF HOIST WITH PROFIBUS-DP INTERFACE

Zhang Mingming<sup>1\*</sup>, SunManman Jiang Xiaoqi<sup>2</sup>, You Qianliang Lu Jiaqi<sup>3</sup>

<sup>\*1, 2, 3</sup>School of Electronics and Information, Jiangsu University of Science and Technology Zhenjiang 212000 China

**\*Corresponding Author:-**

---

### **Abstract:-**

*Traditional elevator indicators have been improved for traditional elevator indicators with strict communication requirements, high communication costs, and unsuitable for fieldbus-guided industrial production. That is, the PROFIBUS-DP interface is developed for the traditional hoist multi-level indicator, and the bus bridge is used to complete the communication protocol conversion during the data transmission process, so that it can be added to the field bus production system. This paper deals with the design of the multi-level indicator hardware circuit of the hoist with PROFIBUS-DP interface and the design of the software circuit. Finally, the system test platform was built to verify that the hoist indicator structure is simple and reliable.*

**Keywords:-**PLC ; PROFIBUS-DP ; Bus Bridge ; Hoist Indicator

**CLC number:** TD67

## 0 INTRODUCTION

At present, the extensive use of fieldbus has promoted a group of companies with a vision and strength in the field of mine automation to research and develop a series of equipment and equipment based on fieldbus technology and use it in the mining production process. In order to meet the communication requirements of the fieldbus, various instruments need to develop PROFIBUS-DP interfaces for instruments and production equipment. Literature [1-3] describes a special communication chip AnyBus-IC as the system communication processor, which converts the transmission data obtained from the field bus into serial data, sends it to the MCU, and the MCU performs data processing, and finally transforms into the characters that need to be displayed. The literature [4-5] uses the PROFIBUS-DP protocol chip SPC3 and 51 MCU to develop a protocol conversion with PROFIBUS-DP interface through software-based design. Literature [6] proposed a slave interface design scheme using a microcontroller and a PROFIBUS protocol chip as core components. In [7], the VPC3+C chip is used to implement the PROFIBUS-DP protocol, and the ATmega162 microcontroller is used as the control chip to complete the hardware design of the intelligent slave interface. The literature [8-9] outlines the completion of PLC implementation of DP communication in the Profibus-DP fieldbus production system, which can improve the stability, safety and production efficiency of the elevator control system. This article adds a bus bridge to the existing elevator indicator and adds it to the peripheral circuitry in the fieldbus system. The core is to use the bus bridge to complete the protocol conversion between the PLC and the hoist indicator to complete the system data exchange communication.

### Overall Study of Hoist Multi-Level Indicator

By extending the DP interface to the multi-level indicator of the hoist, the system can rely on the bus bridge to realize the data transmission with the PLC of the main station, and then perform verification according to the PLC data that has been received and pass the arrow digital tube on the display panel. The position digital tube displays in real time. According to this description, a block diagram of a multi-level indicator structure with a DP interface hoist is designed as shown in FIG.

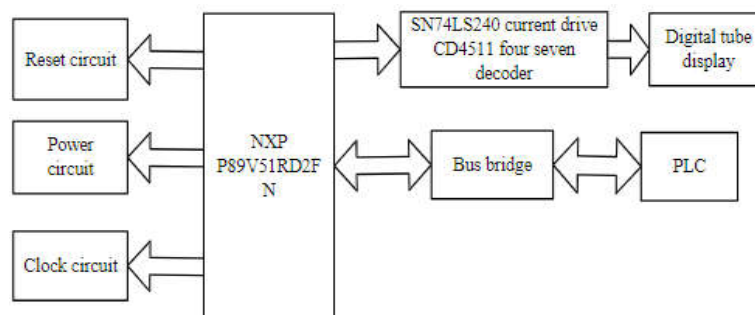

Fig.1 A block diagram of the multi-level indicator with PROFIBUS -DP interface

The traditional hoist indicator includes two modules, a display module and a control module, the display module completes the display function, and the control module completes signal processing and display circuit control. The design module adds a bus bridge processing circuit and a corresponding field bus connection port on the original basis. Its function is to complete the data transfer protocol conversion of the fieldbus production system and the elevator indicator. The specific implementation is to complete the conversion of the device with the asynchronous serial communication interface of the UART serial port to the PROFIBUS-DP communication protocol.

## 2 Hoist Multi-Level Indicator Hardware Design

### 2.1 Overall hardware structure of the hoist multi-level indicator

The hardware part of the hoist multi-level indicator is mainly composed of the following parts: 1. Display circuit: display content has risen and fall, depth digital display indication information; 2. Control circuit: select NXP series single-chip microcomputer to form the minimum system of single-chip microcomputer, and process the data; 3. Slave address switch; set the slave address of each hoist multi-level indicator system; 4. Power circuit: provide +24V to +5V power supply for the system;

### 2.2 hoist indicator control panel

The P89V51RD2FN of NXP is used, and the smallest single-chip system composed of the single-chip microcomputer is the core of the control board. In addition, the control board also includes power supply circuit, D-type port, control module, and slave DIP switch.

### 2.3 hoist indicator display panel

The design function of the hoist multi-level indicator display circuit is to display various information obtained by the indicator controller. The specific display board hardware design consists of two parts; The first part is the direction indication of the hoist movement, which has three states: up and down and off. Used to display the operating status of the hoist The second part is the position display of the hoist. There are two special digital tubes, which are seven-segment common cathode digital tubes. They can display up to 19 layers on the highest floor. The digital tube display

driver chip used in this module design process is SN74LS240 for arrow digital tube and single digit. The tube is displayed.

### 2.4 Bus Bridge

This design is a multi-level indicator with PROFIBUS-DP interface hoist. The core is how to use the bus bridge to provide PROFIBUS-DP communication interface for hoist multi-level indicator. This design uses the PB-OEM2-SE fieldbus interface board. The PB-OEM2-SEbus Bridge embeds the microprocessor and the dedicated DP protocol conversion chip SPC3. This product can be used to complete data communication with a variety of microcontroller interfaces currently on the market.

### 2.5 hoist indicator module interface connection

PLC and bus bridge communication rely on RS-485 transmission technology through D-type port, and pins 3 and 8 are PROFIBUS data lines B and A for exchanging PROFIBUS data. The bus bridge and the single chip transmission mode are serial transmission. The wiring method is shown in Figure 2.

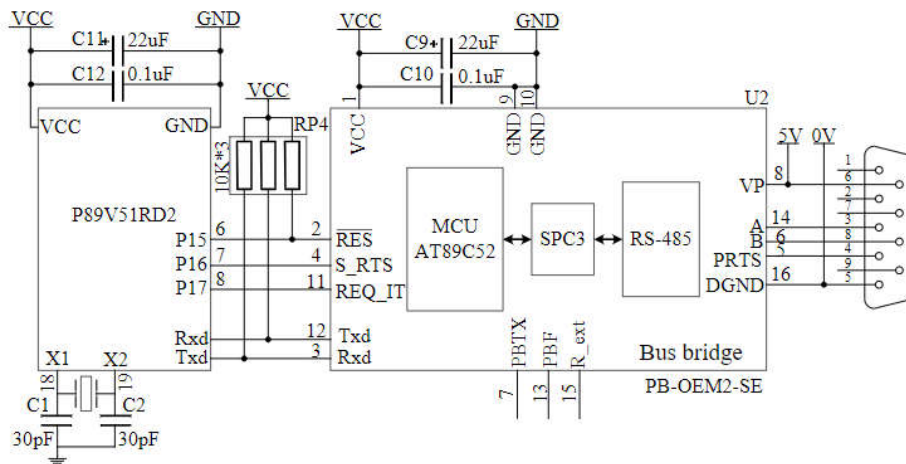

Fig.2 Schematic diagram of the elevator indicator PROFIBUS-DP interface

## 3 Hoist Multi-Level Indicator Software Design

### 3.1 Overall structural design of the system software

The bus bridge is used to realize the data transmission function of the PLC and the single chip by extending the DP interface to the hoist indicator. The software part related to the completion of this function is designed in two parts. The first part is the initialization procedure of each module. Initialization of the Bus Bridge and serial port initialization is the most basic. The second part is the process of data transmission. The software relationship between the control board MCU and other devices in this design is shown in Figure 3.

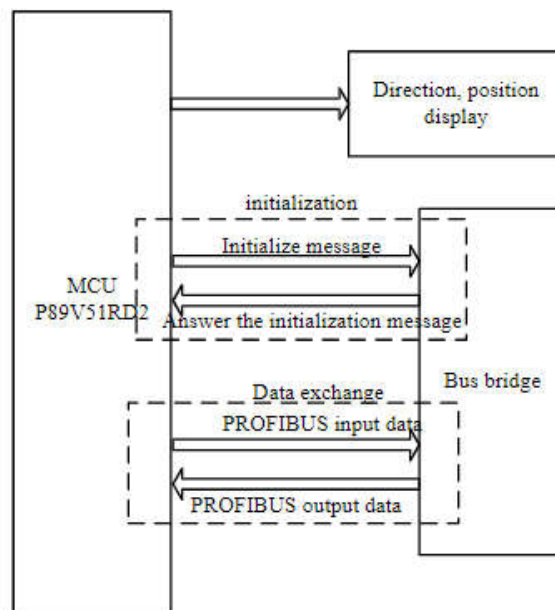

Fig.3 The elevator indicator controller interfaces with each part of the software

### 3.2 Initialization and data communication

The initialization of the serial port and the bus bridge plays an important role in the system initialization process. If you want to complete the initialization of the bus bridge, you need to know the status signals of the two pins of REQ\_IT and S\_RTS. And the corresponding transmission conditions corresponding to them. The specific process is shown in Figure 4.

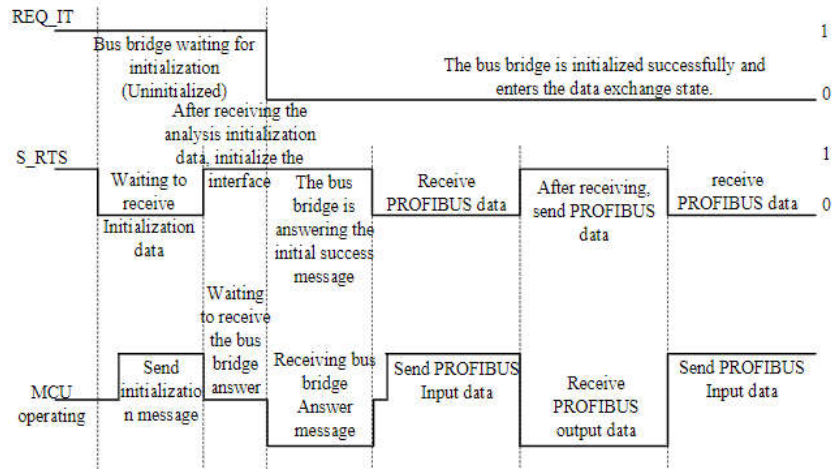

Fig.4 REQ\_IT and S\_RTS pin timing diagrams

The bus bridge is initialized by judging the status signals of the two pins of EQ\_IT and S\_RTS. The specific flow chart is shown in FIG. 4

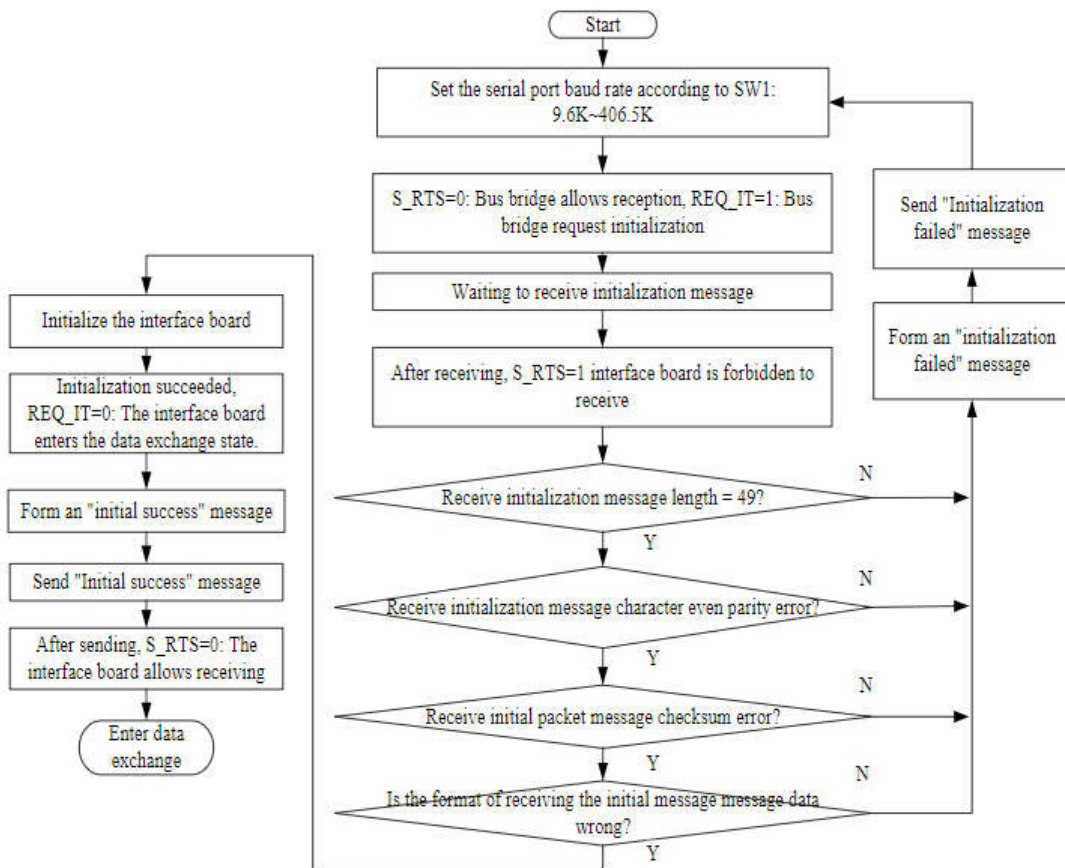
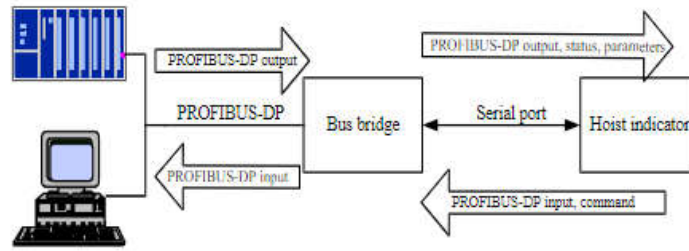

Fig.5 Bus bridge initialization flow chart

### 3.3 hoist multi-level indicator system data exchange

After the initialization of each module is completed, the elevator controller indicator and the PLC start the data exchange process of the system. At this time, according to the communication protocol, the hoist control module will actively transmit the input data message to the bus bridge, the message contains the PROFIBUS input data; the bus bridge passively responds to the message, and the message contains the output data of the PROFIBUS, the specific process As shown in Figure 6 below.



**Fig.6 Master and slave data transmission when the message status**

The hoist controller and the bus bridge perform periodic data exchange, and the control board first sends data exchange messages. The message mainly includes three parts: request data command, PROFIBUS input data length requirement, and system checksum. The bus bridge gets the message sent by the controller to check whether the request data command is correct. The bus bridge then sends a data output message. It also includes: the message type and his interface status, PROFIBUS input data length requirements, and the request data command and system checksum. After the initialization is completed, the hoist multi-level indicator receives the PLC data transmitted through the bus bridge, performs decoding and judgment according to the data transmitted by the PLC, and then displays the position of the hoist and the running direction. The software flow chart is shown in Figure 7.

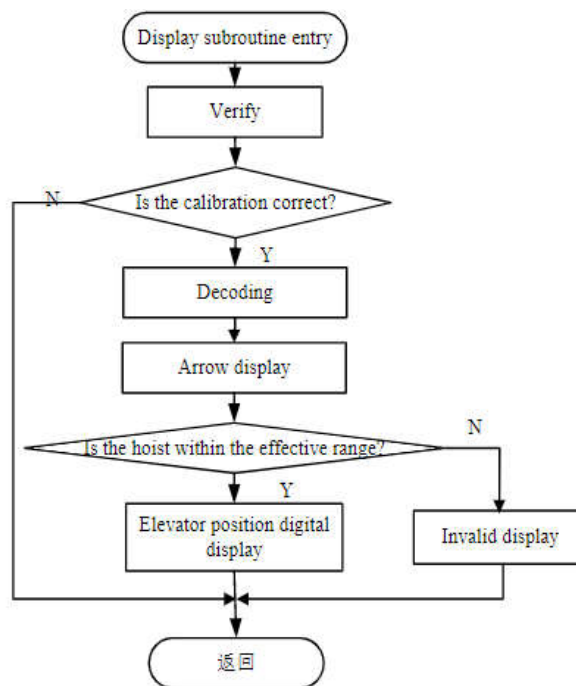

**Fig.7 Data display flow chart**

The display function is called by the interface program to check the received data. After the verification is completed, the data is processed and decoded, and it is judged whether the data to be displayed is within the displayed range. If it is on the 1st to 19th floors, the display panel is displayed in full accordance with the data transmitted from the PLC.

### 3.5 About bus bridge product GSD

In this communication system of the hoist multi-level indicator, the bus bridge needs to write a GSD file. The GSD file is used to describe the characteristics of the PROFIBUS-DP type device. The performance characteristics of various instruments of PROFIBUS are mostly different. In order to make us more convenient, the fieldbus products are more versatile. This requires that the basic requirements and features of the fieldbus instruments we use must be reflected in the GSD. The GSD file contains various performance indicators of the bus bridge used, such as the GSD file version, the name of the product when the product manufacturer name is configured, the product version number, the ID number, the software and hardware version, and some requirements for data transmission. The PB-OEM2-SE product used in this design has been filed in the international PROFIBUS organization PI, and has obtained the PI grant ID number: 06FA and GSD file name: DS\_06FA.GSD

## 4 System experimental platform

### 4.1 platform construction

The experimental platform for the design of the system is constructed as shown in Figure 8

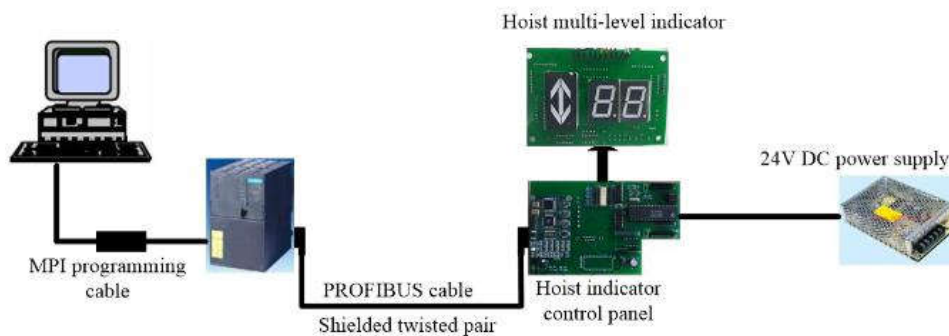

**Fig.8 The construction of the experimental platform**

The test platform is built mainly in the following parts: 1. Install the S7-300 software. Using a laptop to program the PLC, the PLC selected in this design has a programming dedicated port MPI connection notebook for online simulation; 2. Connect the DP port of the PLC to the D port of the control board and the bus bridge by RS485; 3. Use the jumper to connect the hoist multi-level indicator control board and display panel according to the schematic diagram; 4. Using a programmer to program the NXP microcontroller; 5. The 24V DC power supply supplies power to the control board and the PLC. The 5V power supply is found from the control board and connected to the indicator display board with a jumper for power supply.

#### 4.2 Experimental results

The experimental platform of the system design is completed. According to the design requirements, the communication of the whole system can be completed and the system main station PLC can transmit two four-digit values to the display module control circuit. The MCU can check and translate the acquired data. Code operation. The display circuit displays the up and down running status and the position of the floor where the hoist is located. High-speed and reliable data communication between the elevator indicator with DP interface and PLC is realized.

#### 5 Conclusion

The main purpose of this design is to complete the design of the hoist multi-level indicator. A conventional elevator multi-level indicator is added to the DP interface, and PROFIBUS-DP is used for high-speed data transmission at the field level, and the primary station periodically reads the input information of the slave and periodically transmits the output information to the slave. The main task of the designed product receives the data transmitted from the PLC to the indicator control board and is processed by the MCU, and then the indicator shows the position and direction of the hoist. By adding a PROFIBUS-DP interface to the hoist indicator. Use the bus bridge to complete the design requirements and build an experimental platform to complete the data transfer. It solves various defects of the traditional hoist in the past, such as high communication cost, low reliability, and relatively slow transmission rate.

#### References

- [1]. Tian Hongfang, Li Yinghong. Design of hoist depth indicator based on PROFIBUS-DP [J]. Journal of Scientific Instrument, 2005, 26(z1): 429-431.
- [2]. Ouyang Danna. Development of mine hoist depth indicator based on PROFIBUS-DP [D]. North China University of Technology, 2006.
- [3]. Li Lifeng, Bai Hongfeng, Ren Honglan. Development of Deep Display Device with Field Industrial Bus Interface [J]. Coal, 2011, 20(8): 78-80.
- [4]. Zhou Yiming. Research on PROFIBUS-DP Fieldbus Communication and Intelligent Slave Design [D]. Nanjing University of Aeronautics and Astronautics, 2005.
- [5]. Jiang Ping. Research and development of key technologies for PROFIBUS-DP intelligent slave station [D]. Tianjin University of Technology, 2007.
- [6]. Wu Zhenggao. Research on intelligent slave interface based on PROFIBUS-DP fieldbus [D]. Guilin University of Electronic Technology, 2012.
- [7]. A Lianxiang, Cheng Le, Yao Bin. Design of hoist automation system based on PROFIBUS DP [C]// 2010 'China Mining Technology Conference Proceedings. 2010.
- [8]. Zhang Junwei. Research and design of mine electric control system based on Profibus bus [D]. Henan Polytechnic University, 2011.
- [9]. Cheng Mengling, Pang Kewang, Si Yuhua. Mine Hoist Control System Based on Profibus-DP Fieldbus [J]. Metal ore journal, 2013, 42(9): 132-134